



Gunnebo Centurion LW-SR

Exceptionally lightweighted and burglary resistant, modular strong room panels

The Centurion lightweight strong room offers exceptional lightweight performance without compromising on burglary resistance, leveraging the latest available technologies to withstand even the most sophisticated attacks. The modular strong room panels are certified as Grade V by the European Certification Board Security Systems (ECB·S), in accordance with the EN 1143-1 standard. To obtain this certification, a variety of tools, such as crowbars, drills, sledgehammers and oxy-

acetylene torches are used to put the vault's ability to withstand break-in to the test. The very lightweight modular strong room panels reduce transportation costs and facilitate an easy and quick assembly. The certified lightweight solution has been specifically designed to address strong room projects for which a lower floor loading restriction is imposed – such as upstairs or in an historic building, and where standard vaults cannot be installed.

Centurion Lightweight Strong Room Panels, Grade V

Modular construction

Gunnebo's high-security strong rooms are constructed by combining at least one vault door with modular wall, floor and ceiling panels. The components are mounted together for a strong room that maximises available space, whether in a new or in an existing construction.

Customisable design

Gunnebo experts are trained to assess the constraints of each project, from difficult access and old buildings to rooms with unusual dimensions and floor-load limitations. They define the specifications of each strong room and devise a solution that meets all customer-specific requirements.

Key Features

- Panels are certified as Grade V by the European Certification Board Security Systems (ECB-S), in accordance with the EN 1143-1 standard
- Next to the steel reinforcements, the panels contain a newly developed high-strength concrete and wood pieces that allow for a lighter weight and environmentally friendly approach (no use of bitumen or any toxic components)
- Reduced wall thickness to maximise available space
- Innovative, ECB-S-certified ventilation system for optimum climate control
- Optional planar protection
- Interior finished with primed surface; exterior finished with steel (optional)

Key Specifications

Net Weight (kg/m ²)	Thickness (mm)	Wall/Roof, max. Height/Length (mm)
175	80	4000

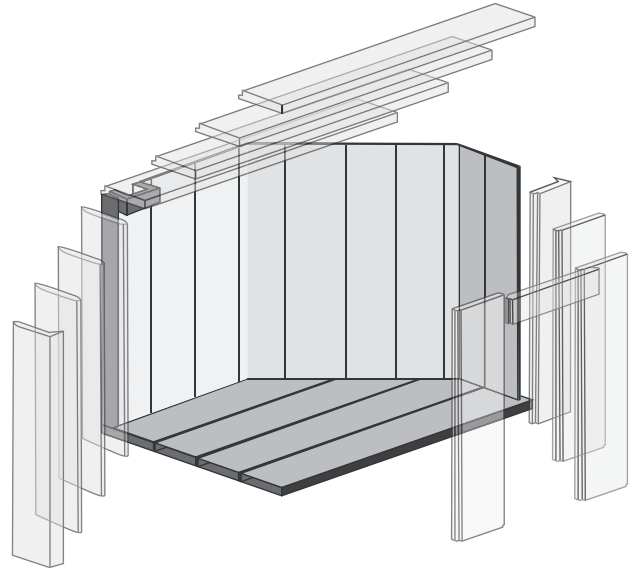

Resistance meets convenience

The Gunnebo Centurion range of strong rooms and vault doors combines performance and flexibility in one high-performance solution. Each range has a variety of adaptable components that have been tried-and-tested to resist attack and can be customised to meet specific customer needs. The Centurion strong rooms and vault doors benefit from the following:

State-of-the-art technology

Centurion high-security vault rooms leverage the latest-available technologies to withstand even the most sophisticated attacks. The very lightweight panels of the Centurion LW-SR reduce transportation costs and facilitate an easy and quick assembly. At the same time, Centurion strong rooms and vault doors are designed to optimise simplicity and accessibility for a solution that is user-friendly and easy to operate.

Advanced testing for a high-level security certification

The Centurion light weight strong room is certified by the European Certification Board Security Systems (ECB-S), in accordance with the EN 1143-1 standard. To obtain this certification, a variety of tools, such as crowbars, drills, sledgehammers and oxyacetylene torches are used to put the vault's ability to withstand break-in to the test.

Centurion Lightweight Vault Door, Grade V–VI

An impenetrable gate for your strong room

The Centurion lightweight vault door is the ideal complement to the lightweight Grade V strong room, as it offers the same exceptional lightweight performance without compromising on burglary resistance. The door is certified as Grade V and VI by the European Certification Board Security Systems (ECB-S), in accordance with the EN 1143-1 standard. Seven and thirteen active front bolts and two relockers make sure that this door is an impenetrable gate to protect valuables. The very lightweight door reduces transportation costs and facilitates assembly. At the same time, the Centurion light-weight vault door is designed to optimise simplicity and accessibility for a solution that is user-friendly and easy to operate.



Key Specifications

Model	External Height (mm)	External Width (mm)	External Depth (mm)	Clear opening Height (mm)	Clear opening Width (mm)
Grade V	2100	1220	240	1960	900
Grade VI	2100	1220	240	1960	900

Model	Door thickness, massive part (mm)	Door thickness, Cast in-situ (mm)	Net Weight, modular room (kg)	Net Weight, Cast in-situ (kg)
Grade V	90	300	650	630
Grade VI	90	300	920	680

Model	Secured by 2 Locks (KL + CL)	Number of active front bolts	Number of re-locker bolts
Grade V	B + B	7	2
Grade VI	C + C	13	2

Key Features

- Doors are certified as Grade V and VI by ECB-S, in accordance with the EN 1143-1 standard
- A new design that offers an exceptional lightweight performance without compromising on burglary resistance
- The very lightweight door reduces transportation costs and facilitates assembly
- Seven and thirteen active front bolts (30 x 30 mm) and two relockers
- Door frames are armoured to provide extra protection
- The doors are designed to accommodate an alarm system
- Ergonomic design to optimise simplicity and accessibility for a solution that is user-friendly and easy to operate
- Optional grill gate available, accessible via a high-security lock that can be opened manually or automatically
- Door also available as “Door-in-Door” variant with an integrated emergency door, certified as Grade V–VI

Lock Options

Key Locks

- Mauer 70079 (Class B)
- Mauer Primus 70011 (Class C)

Combination Locks

- S&G 6731 (Class B)
- Kaba Mas LG 1947 (Class C)

Electronic Locks

- KelNet (Class B, C, D)
- Kaba Paxos (Class B, C, D)

Finishing options

- RAL 7016 Anthracite Grey
- RAL 7035 Light Grey

Gunnebo Centurion LW-SR

Design and production: Gunnebo. Photos Credits: Gunnebo. The data given in this material may be subject to change without further notice. The Gunnebo logos and "Gunnebo - For a safer world" are registered trademarks of Gunnebo AB.



Take advantage of our knowledge:
www.GunneboSafeStorage.com

GUNNEBO[®]
Safe Storage